



Columbia Research Laboratories, Inc.

1925 Mac Dade Blvd. Woodlyn, PA 19094 U.S.A.
Phone: 1.800.813.8471 / Fax: 610.872.3882
Email: sales@columbiaresearchlab.com

Series 5648 Airborne Charge Amplifiers

FEATURES

- Biased or Unbiased Signal Outputs
- High and Low Gain Signal Outputs
- 10:1, 20-Turn Gain Adjustment Potentiometer
- Choice of Butterworth Low Pass Filters
- Miniature Electronic Packaging

The Columbia Models 5648B and 5648U Charge Amplifiers are designed for use with virtually all piezoelectric transducers to form various airborne vibration and shock data acquisition systems. These devices feature small package size and extremely low power consumption.

The Series 5648 Charge Amplifiers provide dual signal outputs and are available in seven standard charge conversion ranges, each offering a 10:1 tandem gain adjustment capability. A range of low-pass filters are available to meet your individual vibration measurement needs. *Consult the factory for customized versions of these sensors.*

Note: Exports from the United States are subject to the licensing requirements of the Export Administration Regulations (EAR) and/or the International Traffic in Arms Regulations (ITAR).

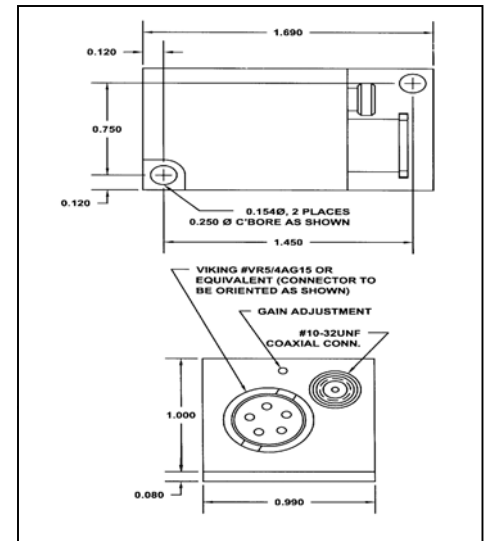

Specifications

INPUT:

Transducer Compatibility	Piezoelectric Capacitive Transducers
Source Impedance	Minimum Input Source Resistance: 25 Megohms
Source Capacity	10,000 pF Max To Meet All Specifications
Overload Recovery.....	5,000 pcmb 1mS Half-Sine, No Effect
Input Connection.....	Single Ended, Referenced to Circuit Ground

OUTPUT:

DC Bias @ Biased Output	+2,500 ±0.075 VDC
@ Unbiased Output.....	0.000 +0.050 / -0.000 VDC
Minimum Linear Output Voltage	4.65V Pk/Pk (1.64 VRMS)
Output Limiting	
Biased Output.....	+5.40 ±0.20 VDC, 0 +0.05 VDC
Unbiased Output	+5.40 ±0.20 VDC, 0 +0.05 VDC
Maximum Linear Output Current	0.500 mA Pk/Pk
Output Impedance	
Biased Output.....	50 Ohms Maximum, Direct Coupled
Unbiased Output	50 Ohms Maximum, 22 µF Coupling Capacitor
Residual Noise Level	5.0 mV RMS Max. Ref: High Gain Output

STANDARD GAIN RANGES

PN Suffix	Conversion Gain Range
P1	0.1 To 1.0 mV/pcmb
P2	0.2 To 2.0 mV/pcmb
P3	0.5 To 5.0 mV/pcmb
P4	1.0 To 10.0 mV/pcmb
P5	2.0 To 20.0 mV/pcmb
P6	5.0 To 50.0 mV/pcmb
P7	10.0 To 100.0 mV/pcmb

LOW-PASS FILTERS

PN Suffix	+/-5% Response	Rolloff
F1	5 Hz To 100 Hz	-12 dB/Oct
F2	5 Hz To 200 Hz	-12 dB/Oct
F3	5 Hz To 500 Hz	-12 dB/Oct
F4	5 Hz To 1000 Hz	-12 dB/Oct
F5	5 Hz To 2000 Hz	-12 dB/Oct
F6	5 Hz To 5000 Hz	-12 dB/Oct
F7	5 Hz To 10000 Hz	-12 dB/Oct

TRANSFER CHARACTERISTICS:

Gain Range	0.10 To 100.0 mV/pcmb (Refer to Gain Chart)
Gain Adjustment	Single 20-Turn Screwdriver Adjust Potentiometer
Gain Ratio	10:1 High Gain vs. Low Gain $\pm 2\%$
Gain Stability vs. Temperature	$\pm 2\%$ Max Over Operating Temperature
Gain Stability vs. Input Capacity	Less Than 0.10% / 1000 pF
Frequency Response	$\pm 5\%$, 5 Hz To 10KHz (Refer to Filter Chart)
Filter Configuration	Low Pass -12 dB/Octave (Selectable)
Filter Enable	Factory Installed
Total Harmonic Distortion	1% Max
Amplitude Linearity	1% Max B.F.S.L.
Calibration Input	Optional, Consult Factory
Warmup Time	30 Seconds Max To Meet All Specifications

POWER REQUIREMENTS:

DC Supply Voltage	+22 To +32 VDC, +28 VDC Nominal
Supply Current	25 mA Max
Power Ground / Signal Ground Isolation	Common, Connected Internally
Case Ground Isolation	Circuitry Isolated by 50 Megohms Min. @ 50 VDC

PHYSICAL CONFIGURATION:

Case Material	2024-T4 Aluminum Alloy
Case Finish	Nickel Plate Per MIL-C-26074, Class 3
Input Connector	Double Isolated 10-32 Coaxial
Output Connector	Viking VR5-4AG15, 5-Pin Cylindrical
Case Mounting	(2) #6 Thru Holes for 6-32 Socket Head Cap Screws
Weight	50 Grams Max.

ENVIRONMENTAL LIMITS:

Operating Temperature	-55 To +100 Deg. C
Storage Temperature	-55 To +125 Deg. C
Humidity	Hermetic-Grade Epoxy Seal
Vibration	20 G Pk, 50 Hz To 2KHz
Shock	100 G Pk, 6.5 mS Sawtooth Pulse
Altitude	200,000 Feet Max.

I/O Connector Pin Functions:

5648B	
<i>Pin</i>	<i>Function</i>
A	+28 VDC
B	1-10 Biased Output
C	10-100 Biased Output
D	Signal & Power Ground
E	Case Ground

5648U	
<i>Pin</i>	<i>Function</i>
A	+28 VDC
B	1-10 Unbiased Output
C	10-100 Unbiased Output
D	Signal & Power Ground
E	Case Ground

Ordering Information:

