



# Strain Sensors

## Series DT3625

Columbia's Strain Sensors measure fatigue loading experienced by aircraft under various conditions of speed, weight and mission configuration more accurately than by older, less accurate counting accelerometer methods. These sensors allow critical undercarriage structures and surfaces to be more accurately monitored for potential fatigue damage induced by thousands of flight hours, high stress maneuvers and landings. The simplicity and reliability of these sensors also makes them suitable for routine use in the laboratory.

Series DT3625 sensors were developed in response to the need for fatigue measurements in tight spaces, and these sensors offer all the accuracy, ruggedness and ease of installation of the flight-qualified Series DTD2684 sensors. Models are available to compensate materials commonly used in aircraft structural fabrication. Columbia Model 5802 Strain Gage Amplifier is designed to amplify the sensor signals providing both strain and temperature outputs.

Note: Exports from the United States are subject to the licensing requirements of the Export Administration Regulations (EAR) and/or the International Traffic in Arms Regulations (ITAR).

### Specifications<sup>1</sup>

Series DT3625	
<b>Operational</b>	
Input Resistance	1000 ohms, ±2%
Sensitivity	(±1%); 1.025 mV/V/1000µε
Rated Excitation Voltage	10.0 VDC
Linearity	±0.5% Max.
Zero Offset	±0.5 mV/V Typical
Operating Range	-3500 to +5000 µε
Output Resistance	1000 Ohms, ±2%
Sensitivity Shift	±0.005% / °F
Hysteresis, Repeatability	±0.013% Max.
Zero Shift	±0.00025 mV / V / °F Typical
Creep	<0.5%, 5 Min. @5000 µε
<b>Environmental<sup>2</sup></b>	
Temperature Range	-54° to +125°C
Vibration	30g, 10Hz to 2KHz
Humidity	MIL-STD-202 Method 103B
Salt Spray	MIL-STD-202, Method 101D (168 Hours)
Insulation Resistance	100 Meg. min. @ 500VDC
Dielectric Strength	1050 VRMS, 60Hz, 1 Min.
Altitude	Sea Level to 70,000 Ft.
Shock	100g, 11msec.
Flammability	MIL-Std-202 Method 111A
Fluids	Resistant to short term exposure to fuel, lubricating oils and hydraulic fluids.
<b>Physical</b>	
Size	0.45" x 0.25" x 0.14" thick
Encapsulant	Silicone rubber per MIL-S-23586A Type 1 Class 2, Grade A
Weight	13 grams
Matrix	0.001" Polyimide
Leads	#26 AWG, Teflon ins, SPC, 12" Min.

- Smallest Size
- Self Temperature Compensating
- Ease of Installation
- High Output – Two Active Arms

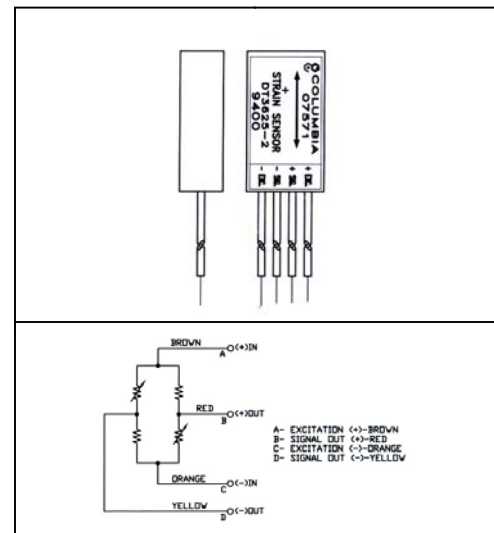

### Ordering Information:

Model	Compensating Material	Lead Length
DT3625-1	Aluminum 7075-T6	48 Inches
DT3625-2	Steel, AISI 4130	48 Inches
DT3625-3	Titanium TI-6AL-4V Annealed	48 Inches
DT3625-4	Graphite Epoxy AS4/3501-6	48 Inches
DT3625-5	Steel, Aermet 100	48 Inches

Fig. 2 Installation of Columbia Strain Sensor

1. Strain Sensor bonded to surface under test.
2. Leads connected to wire harness.
3. Coat sensor and wires with waterproofing material.

### ADVANTAGES

- Higher level accuracy
- Twice the output
- Less installation time
- No loss of structural integrity
- Optimum temperature compensation

<sup>1</sup> at +25 Deg. C    <sup>2</sup> Installed Gage

Fig. 1 Typical Installation of Old Style Strain Gages

1. Bolt or rivet removed from assembly
2. Dummy gage(s) bonded to "Z Tab" of same material as structure.
3. Active gage bonded to structure under test.
4. "Z Tab" mounted to structure with bond or rivet.
5. Strain gage leads intertwined and soldered to junction block.
6. Entire unit covered with protective material.

